



**DECOALA**

New **SPC**  
Generation  
Flooring

**SPC FLOORING**  
**COLLECTION**

a touch of mother nature



New **SPC**  
Generation  
Flooring

[www.decoala.com](http://www.decoala.com)

   #decoala.com.tr

WE AS THE 'DECO ALA' FAMILY, ARE READY TO SERVE YOU AND REFLECT OUR PASSION TO YOUR DAILY LIVES BY 'IMPROVE YOUR QUALITY OF LIVE'.

# Shared passion, shared reality

It is a 'dream coming true'. Exclusive product designs that reflects our common core values; Quality, durability and Innovation.

We make our passion a reality by marshalling our strenghts and start a lifetime collaboration that goes beyond an usual business partnership.

We are a big family with passion to 'improve quality of life' while taking care over all our stakeholders and environment to live comfortable in a durable world.

**Our vision is reflected in all our businesses; trust and commitment to our customers is our first priority.**

Two business partners with mutual core values and same passion to make it happen.. That was the strong start for Deco Ala where quality, innovation and continous improvement become a key goal for all products of this company. The main reason to start the collaboration in 2010 was bringing all experience and expertise together to create the best possible products that is suitable for Business-to-Business as for Business-to-Consumer markets.

Our products are produced with the european quality standards which is a proof for its durability. Another advantage is the fast delivery times because it is produced in the European timezone and a supply chain process where efficiency is key.

Next to delivering the best quality products which is suitable for everybody, we focused ourselves on a special designed technology where even consumers can buy, install and use the products in one day.

It is important to take care of our environment by producing without pollution of our natural resources and use ecological friendly materials.

Our entire product range is produced with a special technology to contribute to a durable live. All products are 100% recycable and ecological friendly.

# Deco Ala

## Create your world with your style

Deco Ala provide a wide selection that adjusts to every style and time period. You are unique and your style needs to reflect your uniqueness.

We offer you not only a product but the feeling of 'coming home, switching-off from all hectic and start enjoying by wandering off in your own created world that reflects yourself. You can feel our core production value under your feet; 'Quality'. And see where our persistency lays; 'Innovation' A Cutting-edge technology, using the latest features of micro-beveled edges, enhanced **painted bevels & Embossed in Register spotlessly** , which generate the most alluring designs.

4

## Dare to live as the real world

Our floors contain all qualifications to stay resistant to all challenges of daily lives. The entire product range is 100% water and fire resistance.

The Waterproof core, flexible vinyl and protective wear layer allows you to use them safely in all areas where there is a risk to come in touch with water and fire. There is no chance for warp or buckle. Our SPC floorings will keep it's original appearance throughout guaranteed life time. All Deco Ala come with extended lifetime warranty.

## Cutting-edge technology that provides simplicity

With a cutting-edge technology, we make it possible to easily install, maintain and use the floors with joy. With our advanced Unilin patented click systems, floorings can be applied flawlessly.

Effortful installation methods such as gluing or nailing will no longer annoy you, besides there is no need for additional underlayment over outdated floorings. Leave out old-fashioned maintenance concerns and unhealthy adhesive scent. Our flooring planks demand no care all over their service life whatsoever.





New **SPC**  
Generation  
Flooring

7 reasons to start your journey  
with Deco Ala and make our  
passion yours;  
'improve your 'quality of live'

5

Our floors:

- ✓ Resistant to all challenges of daily live
- ✓ Resistant to deformation in all circumstances
- ✓ Water and fire proof
- ✓ UV resistance
- ✓ Easy to install on any surface without additional costs
- ✓ Suitable for heating and cooling
- ✓ Eco friendly
- ✓ 100 % Recyclable

# Diverse & Durable

UV Coating Layer

Wear Layer

Decor Film Layer

SPC Rigid Core

IXPE Underlayment

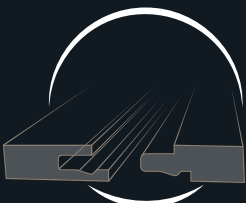

**UNICLIC**  
PATENTED TECHNOLOGY

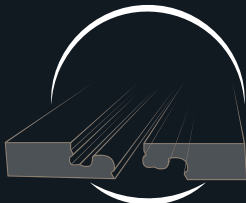

**UNIDROP**  
PATENTED TECHNOLOGY

# Unique IXPE Foam design – feel the quality

To create the right foundation that improves the customers experience and ease of installation, we have added our specially designed IXPE foam as a fixed underlayer for all of our floors.

With this unique design, our customer can feel and hear the quality; it is softer, warmer, and quieter while enjoying life.

This specially designed softness makes it possible to easily install and this results in perfectly laid out floors.

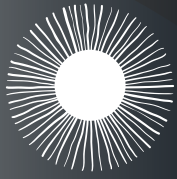

WATERPROOF



QUIET FLOOR



COMFOR TABLE



Improved user experience with a warmer and softer touch.



Cost reduction because no need for a separate underlayment



Perfectly laid out floors by eliminating imperfections



Enhanced noise isolation



Top-class anti bacterial protection

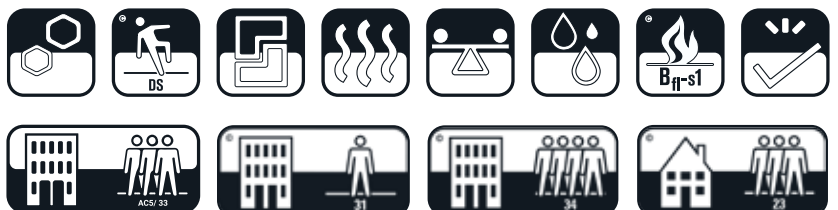

# Inseparable combination

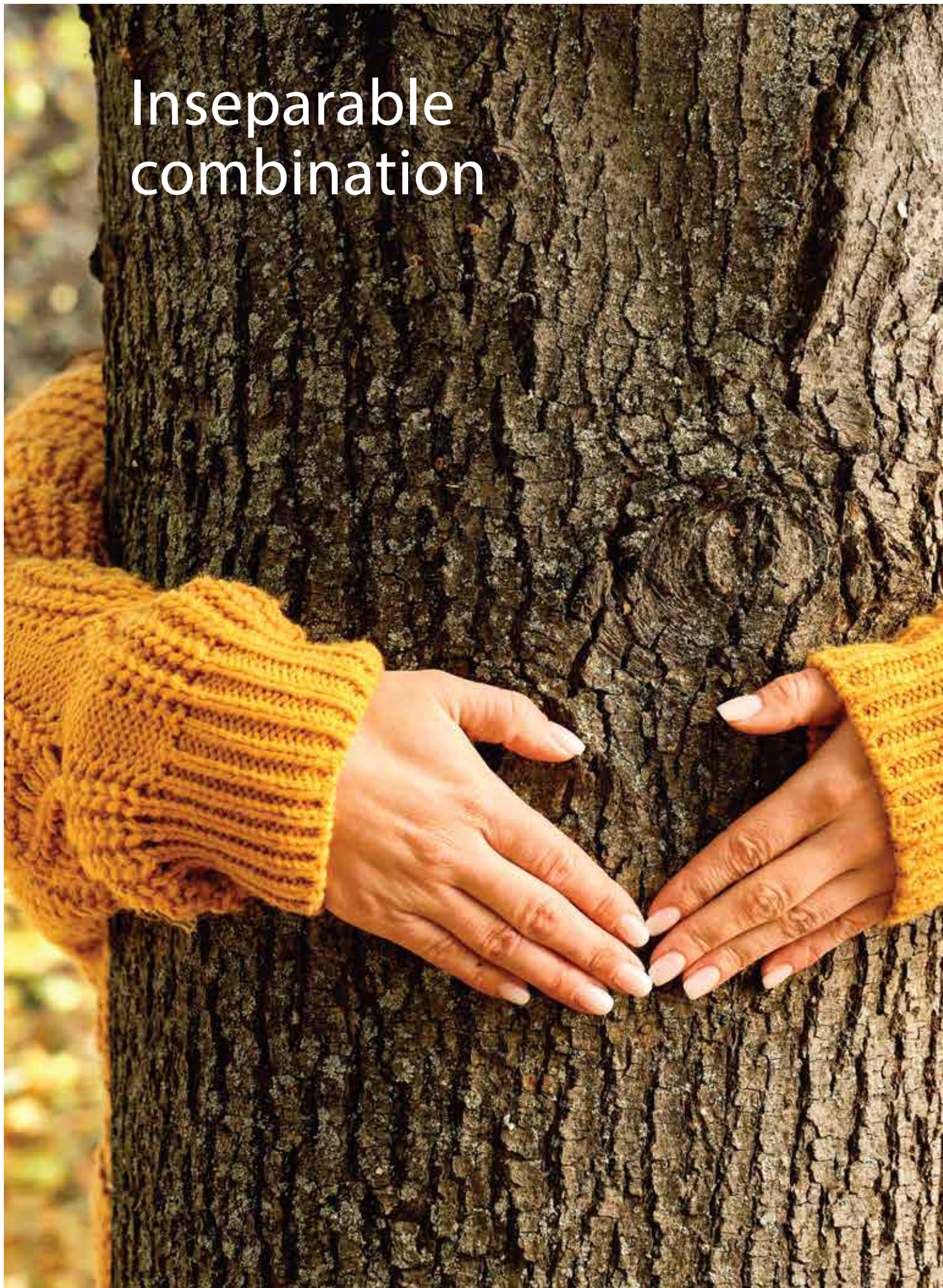



100% Waterproof



Extremely Stable



NO Acclimatisation Necessary



Easy Installation



Installation on any Surface



Reduces Noise



Wear Resistant



Pet Friendly



Electrostatic Performance



Ideal for Underfloor Heating & Cooling

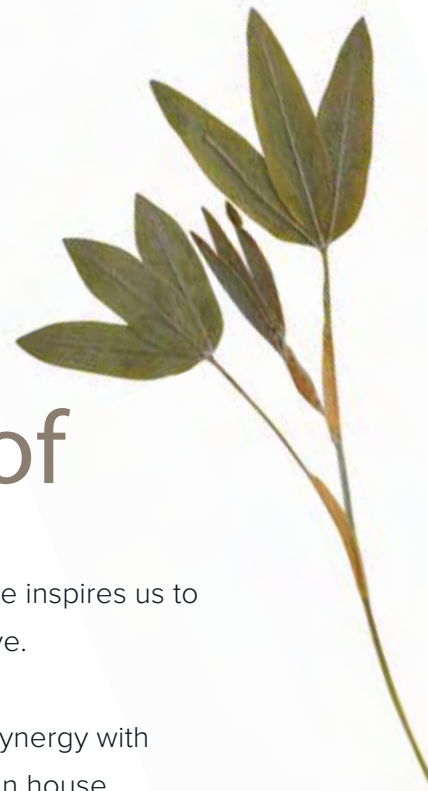

# Enjoy the synergy of

Perfection of color synergy in the nature inspires us to create floors that brings your home alive.

With Deco Ala you create the perfect synergy with the nature outside and your own style in house. No matter your color preference, the captivating and wide range of 'DECO ALA' Spc flooring colors ideally fit any space, interior, and style at your place.

'Let your character speak' with Deco Ala

10



# colors from mother nature



# DECO ALA COLLECTION

WOOD PREMIUM  
SPC COLLECTION  
10 SKU

2

12

WOOD PREMIUM 1  
SPC COLLECTION  
8 SKU



WOOD | WOOD XL

SPC COLLECTION

10 SKU | 10 SKU



STONE & STONE XL

SPC COLLECTION

8 SKU & 8 SKU







# Deco Ala



## AUTHENTIC

## WOOD PREMIUM 1

## WOOD PREMIUM 2

AUTHENTIC		WOOD PREMIUM 1		WOOD PREMIUM 2	
	6.5 mm		5 mm		6 mm
	0.55 mm		0.55 mm		0.55 mm
Plank	Herringbone	Plank	Herringbone	Plank	Herringbone
6 pcs	12 pcs	9 pcs	16 pcs	7 pcs	14 pcs
2.08 m <sup>2</sup>	1.35 m <sup>2</sup>	2.50 m <sup>2</sup>	1.46 m <sup>2</sup>	1.97 m <sup>2</sup>	1.57 m <sup>2</sup>
20.79 kg	13.50 kg	20.20 kg	11.90 kg	19.80 kg	15.90 kg

# Collection Size



WOOD XL		WOOD		STONE	
5 mm		4 mm		5 mm	
0.30 mm		0.30 mm		0.30 mm	
Plank	Herringbone	Plank	Herringbone	Stone XL	Stone
9 pcs	16 pcs	11 pcs	20 pcs	6 pcs	8 pcs
2.50 m <sup>2</sup>	1.80 m <sup>2</sup>	2.44 m <sup>2</sup>	1.83 m <sup>2</sup>	2.23 m <sup>2</sup>	2.97 m <sup>2</sup>
20.20 kg	14.63 kg	19.60 kg	14.70 kg	18.10 kg	23.80 kg



W  
O  
O  
D

16

PREMIUM  
1

100%  
WATERPROOF  
SPC  
FLOORING



# WOOD PREMIUM 1

SPC COLLECTION

EMBOSSSED IN REGISTER

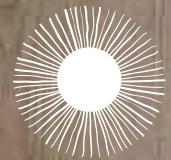
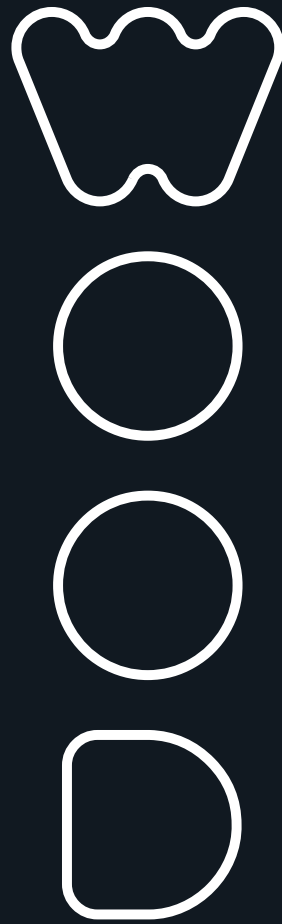

WATERPROOF



QUIET FLOOR



COMFOR TABLE



## 101 AUTUMN OAK



P1-101-PL | PLANK  
228 X 1220 X 5 mm



P1-101-HB | HERRINGBONE  
150 X 610 X 5 mm





## 102 SUMMER OAK



P1-102-PL | PLANK  
228 X 1220 X 5 mm



P1-102-HB | HERRINGBONE  
150 X 610 X 5 mm

# 103 WINTER OAK



P1-103-PL | PLANK  
228 X 1220 X 5 mm



P1-103-HB | HERRINGBONE  
150 X 610 X 5 mm





## 104 SPRING OAK



P1-104-PL | PLANK  
228 X 1220 X 5 mm



P1-104-HB | HERRINGBONE  
150 X 610 X 5 mm





## 105 VINTAGE OAK



P1-105-PL | PLANK  
228 X 1220 X 5 mm



P1-105-HB | HERRINGBONE  
150 X 610 X 5 mm



## 106 COTTON OAK



P1-106-PL | PLANK  
228 X 1220 X 5 mm



P1-106-HB | HERRINGBONE  
150 X 610 X 5 mm

# 107 BLACK OAK



P1-107-PL | PLANK  
228 X 1220 X 5 mm



P1-107-HB | HERRINGBONE  
150 X 610 X 5 mm





## 108 WHITE OAK



P1-108-PL | PLANK  
228 X 1220 X 5 mm



P1-108-HB | HERRINGBONE  
150 X 610 X 5 mm

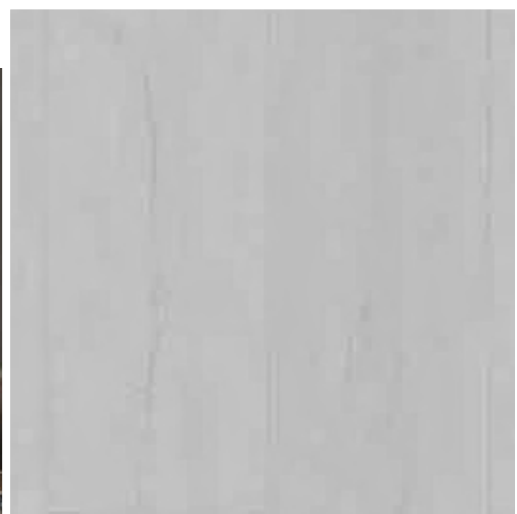



26



# WOOD PREMIUM 2

SPC COLLECTION

EMBOSED IN REGISTER

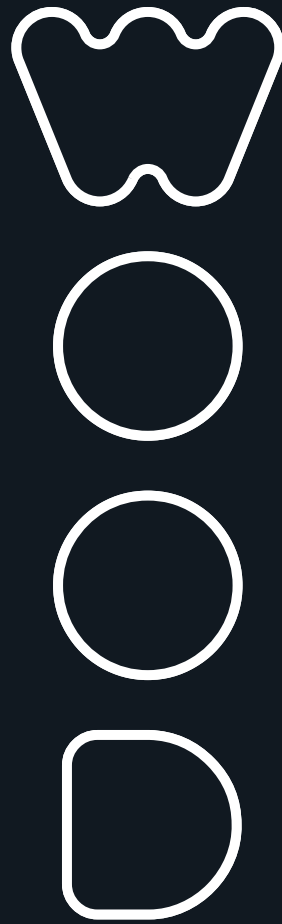

27

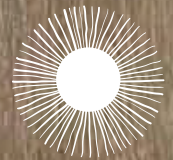

WATERPROOF



QUIET FLOOR

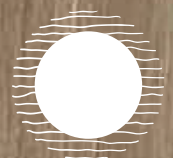

COMFOR TABLE



## 111SEASHORE OAK



P2-111-PL | PLANK  
228 X 1220 X 6 mm



P2-111-HB | HERRINGBONE  
150 X 750 X 6 mm



## 112 PEARL OAK



P2-112-PL | PLANK  
228 X 1220 X 6 mm



P2-112-HB | HERRINGBONE  
150 X 750 X 6 mm

# 113 SELECT OAK



P2-113-PL | PLANK  
228 X 1220 X 6 mm



P2-113-HB | HERRINGBONE  
150 X 750 X 6 mm





## 114 NATURE OAK



P1-114-PL | PLANK  
228 X 1220 X 6 mm



P1-114-HB | HERRINGBONE  
150 X 750 X 6 mm

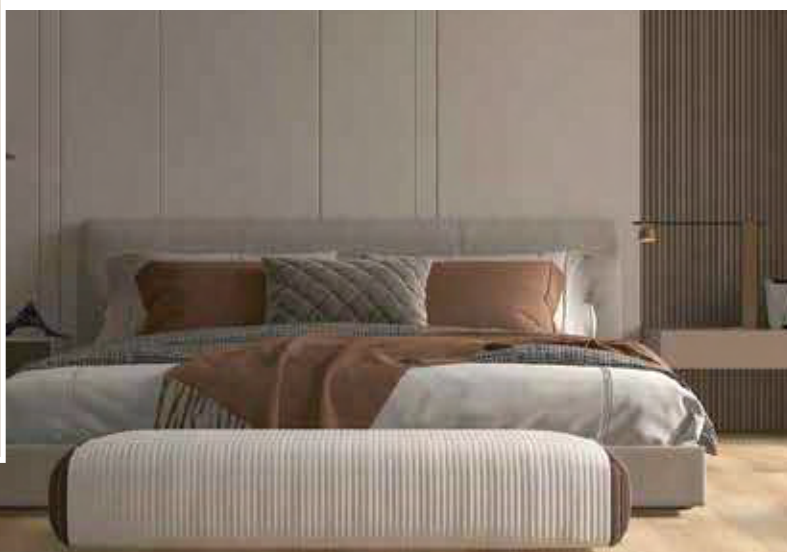



## 115 BOTANIC OAK



P2-115-PL | PLANK  
228 X 1220 X 6 mm



P2-115-HB | HERRINGBONE  
150 X 750 X 6 mm





## 116 CLEAR OAK



P2-116-PL | PLANK  
228 X 1220 X 6 mm



P2-116-HB | HERRINGBONE  
150 X 750 X 6 mm

# 117 BLOND OAK



P2-117-PL | PLANK  
228 X 1220 X 6 mm



P2-117-HB | HERRINGBONE  
150 X 750 X 6 mm

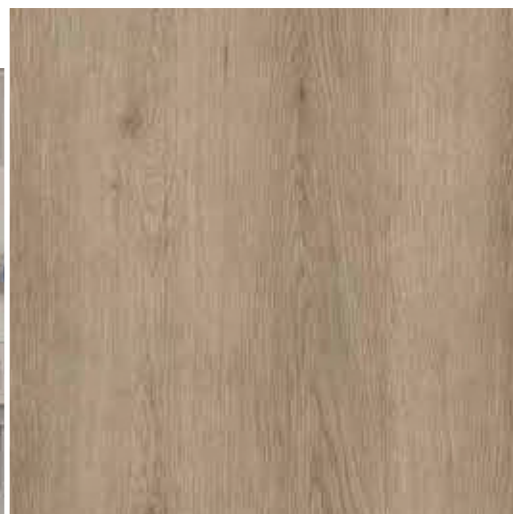



## 118 TAUPE OAK



P1-118-PL | PLANK  
228 X 1220 X 6 mm



P1-118-HB | HERRINGBONE  
150 X 750 X 6 mm





## 119 SAHARA OAK



P2-119-PL | PLANK  
228 X 1220 X 6 mm



P2-119-HB | HERRINGBONE  
150 X 750 X 6 mm



## 120 STORAGE OAK



P2-120-PL | PLANK  
228 X 1220 X 6 mm



P2-120-HB | HERRINGBONE  
150 X 750 X 6 mm

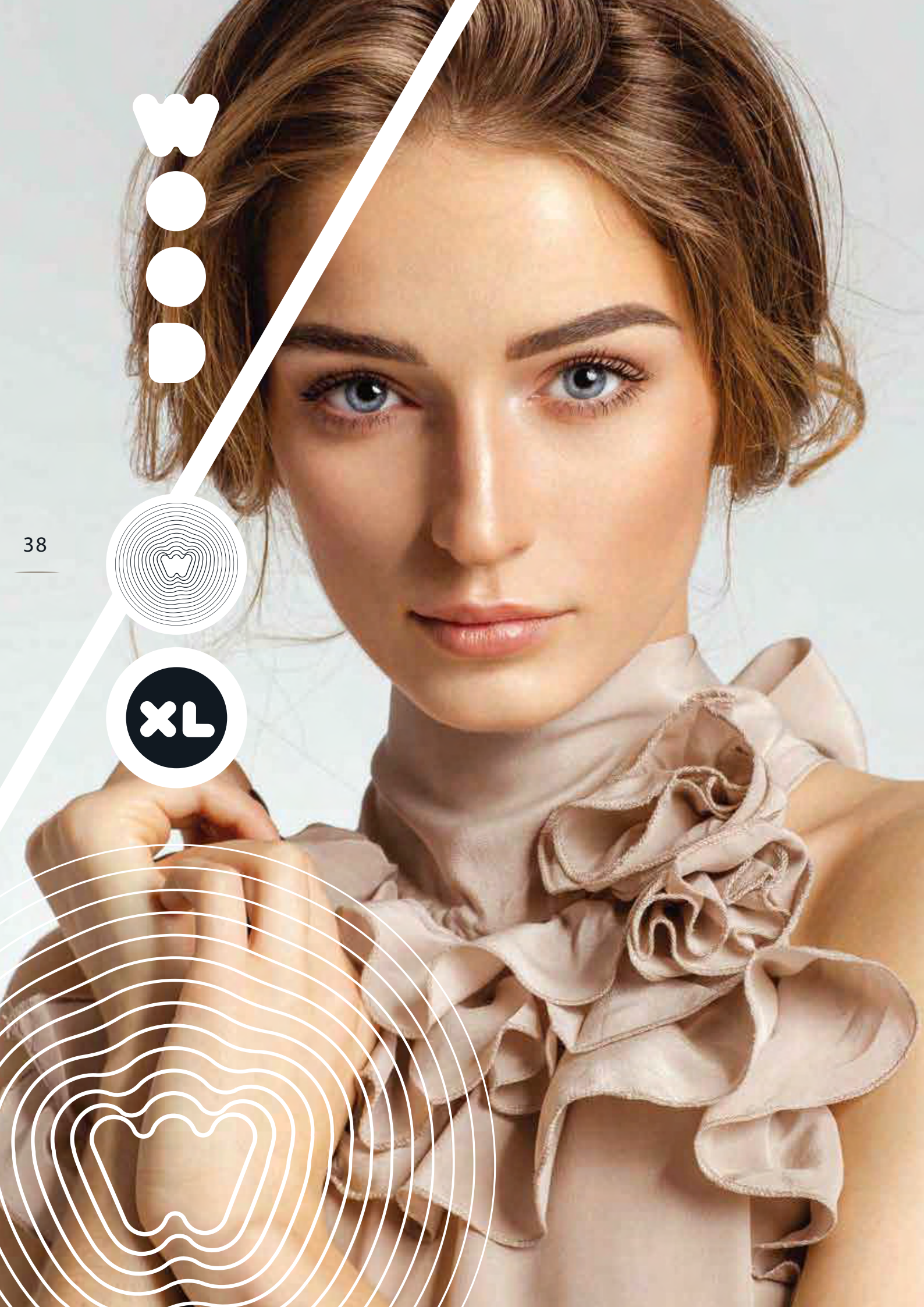

# WOOD | WOOD XL

SPC COLLECTION



WATERPROOF



QUIET FLOOR



COMFOR TABLE

# 201 CANYON OAK



W-201-PL | PLANK  
182 X 1220 X 4 mm

WXL-201-PL | PLANK  
228 X 1220 X 5 mm



W-201-HB | HERRINGBONE  
150 X 610 X 4 mm

WXL-201-HB | HERRINGBONE  
150 X 750 X 5 mm





## 202 DOMINICANO OAK



W-201-PL | PLANK  
182 X 1220 X 4 mm

WXL-201-PL | PLANK  
228 X 1220 X 5 mm



W-201-HB | HERRINGBONE  
150 X 610 X 4 mm

WXL-201-HB | HERRINGBONE  
150 X 750 X 5 mm

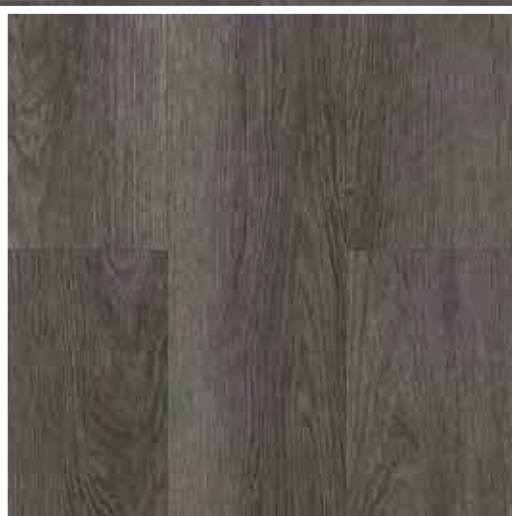

## 203 HAVANA OAK



WXL-203-PL | PLANK  
182 X 1220 X 4 mm

WXL-203-PL | PLANK  
228 X 1220 X 5 mm



WXL-203-HB | HERRINGBONE  
150 X 610 X 4 mm

WXL-203-HB | HERRINGBONE  
150 X 750 X 5 mm

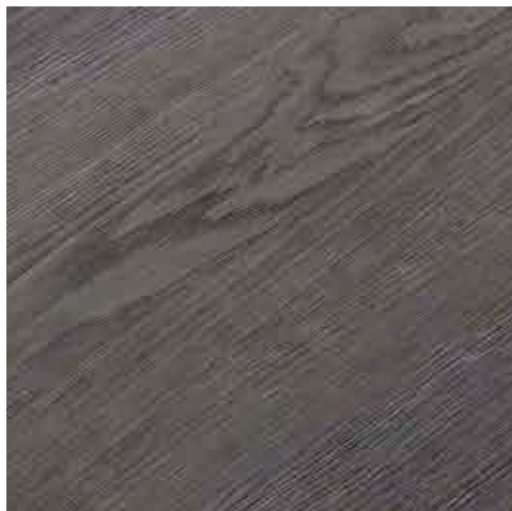

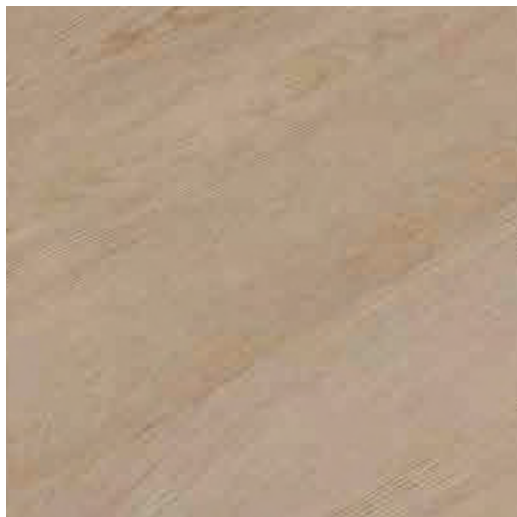

## 204 SLATE OAK



W-204-PL | PLANK  
182 X 1220 X 4 mm

WXL-204-PL | PLANK  
228 X 1220 X 5 mm



W-204-HB | HERRINGBONE  
150 X 610 X 4 mm

WXL-204-HB | HERRINGBONE  
150 X 750 X 5 mm



# 205 BOSLAND OAK



W-205-PL | PLANK  
182 X 1220 X 4 mm

WXL-201-PL | PLANK  
228 X 1220 X 5 mm



W-205-HB | HERRINGBONE  
150 X 610 X 4 mm

WXL-201-HB | HERRINGBONE  
150 X 750 X 5 mm

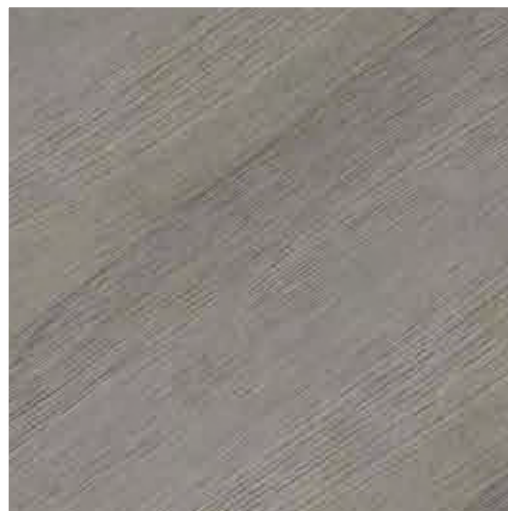



## 206 VALLEY OAK



W-206-PL | PLANK  
182 X 1220 X 4 mm

WXL-206-PL | PLANK  
228 X 1220 X 5 mm



W-206-HB | HERRINGBONE  
150 X 610 X 4 mm

WXL-206-HB | HERRINGBONE  
150 X 750 X 5 mm



## 207 DESERT OAK



WXL-207-PL | PLANK  
182 X 1220 X 4 mm

WXL-207-PL | PLANK  
228 X 1220 X 5 mm



WXL-207-HB | HERRINGBONE  
150 X 610 X 4 mm

WXL-207-HB | HERRINGBONE  
150 X 750 X 5 mm





## 208 WALNUT OAK



W-208-PL | PLANK  
182 X 1220 X 4 mm

WXL-208-PL | PLANK  
228 X 1220 X 5 mm



W-208-HB | HERRINGBONE  
150 X 610 X 4 mm

WXL-208-HB | HERRINGBONE  
150 X 750 X 5 mm

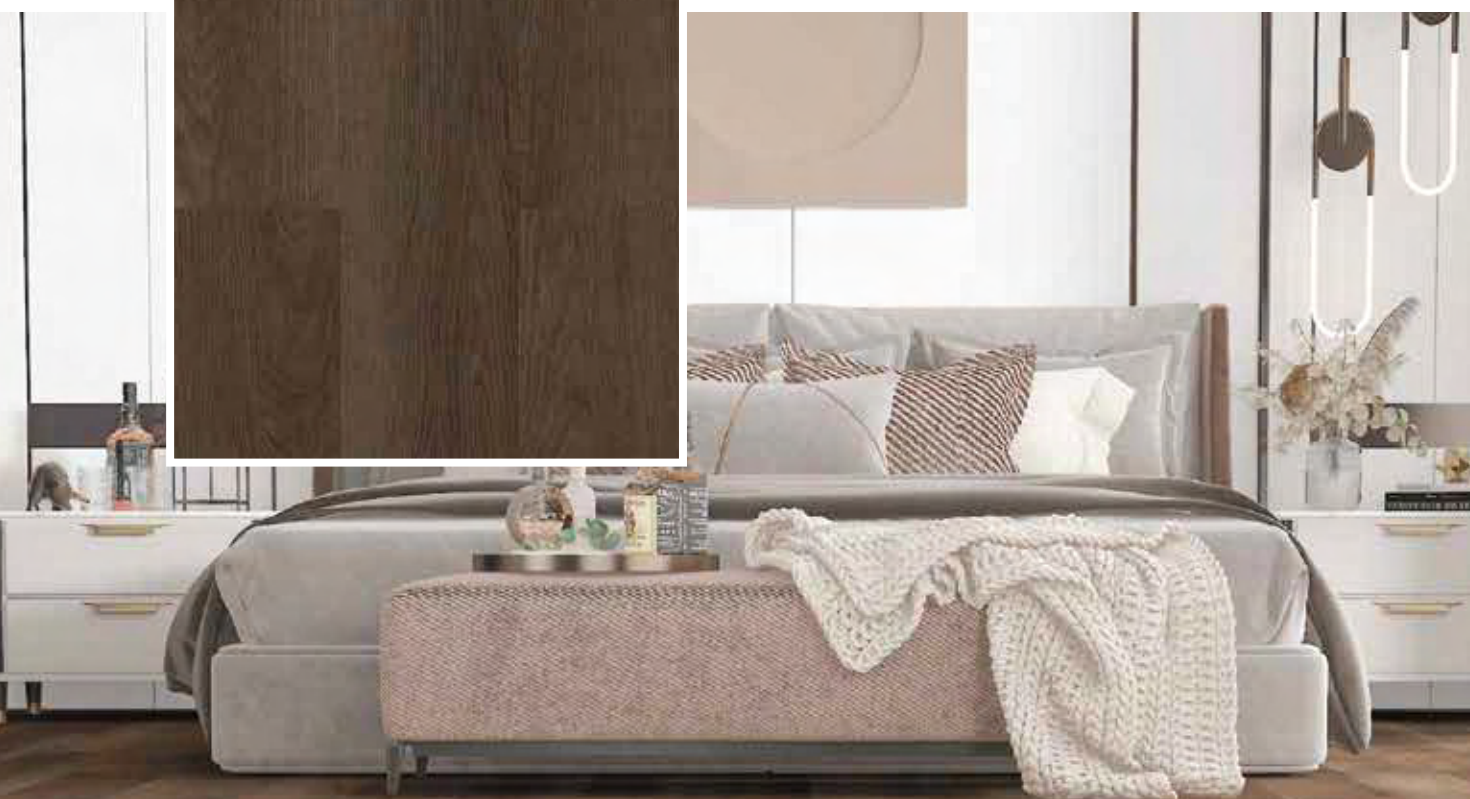

# 209 SCRAPED OAK



W-209-PL | PLANK  
182 X 1220 X 4 mm

WXL-209-PL | PLANK  
228 X 1220 X 5 mm



W-209-HB | HERRINGBONE  
150 X 610 X 4 mm

WXL-209-HB | HERRINGBONE  
150 X 750 X 5 mm





## 210 CAMBRIDGE OAK



W-210-PL | PLANK  
182 X 1220 X 4 mm

WXL-210-PL | PLANK  
228 X 1220 X 5 mm



W-210-HB | HERRINGBONE  
150 X 610 X 4 mm

WXL-210-HB | HERRINGBONE  
150 X 750 X 5 mm

STONE

STONE

XL

50

STONE & STONE XL COLLECTION

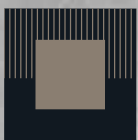

# STONE & STONE XL SPC COLLECTION



# STONE



WATERPROOF

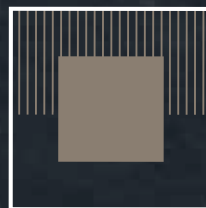

QUIET FLOOR

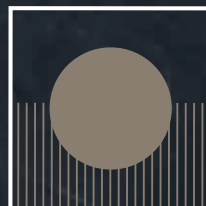

COMFORTABLE

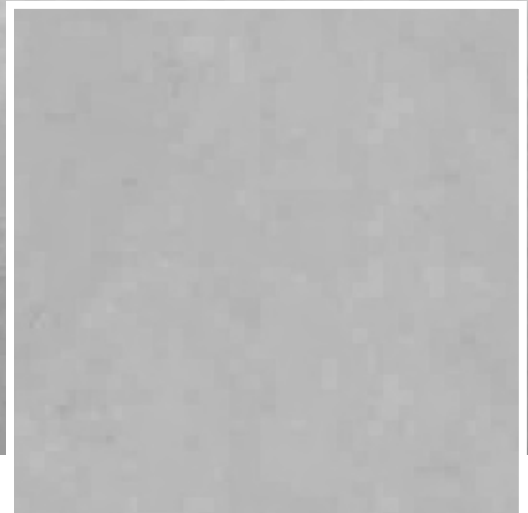

## 801 CONCRETE LIGHT



S-801  
305 X 610 X 4 mm



S-801-XL  
305 X 1220 X 5 mm



## 802 CONCRETE SAND



S-802  
305 X 610 X 4 mm



S-802-XL  
305 X 1220 X 5 mm

# 803 CONCRETE GREY



S-803  
305 X 610 X 4 mm



S-803-XL  
305 X 1220 X 5 mm





## 804 CONCRETE DARK



S-804  
305 X 610 X 4 mm



S-804-XL  
305 X 1220 X 5 mm

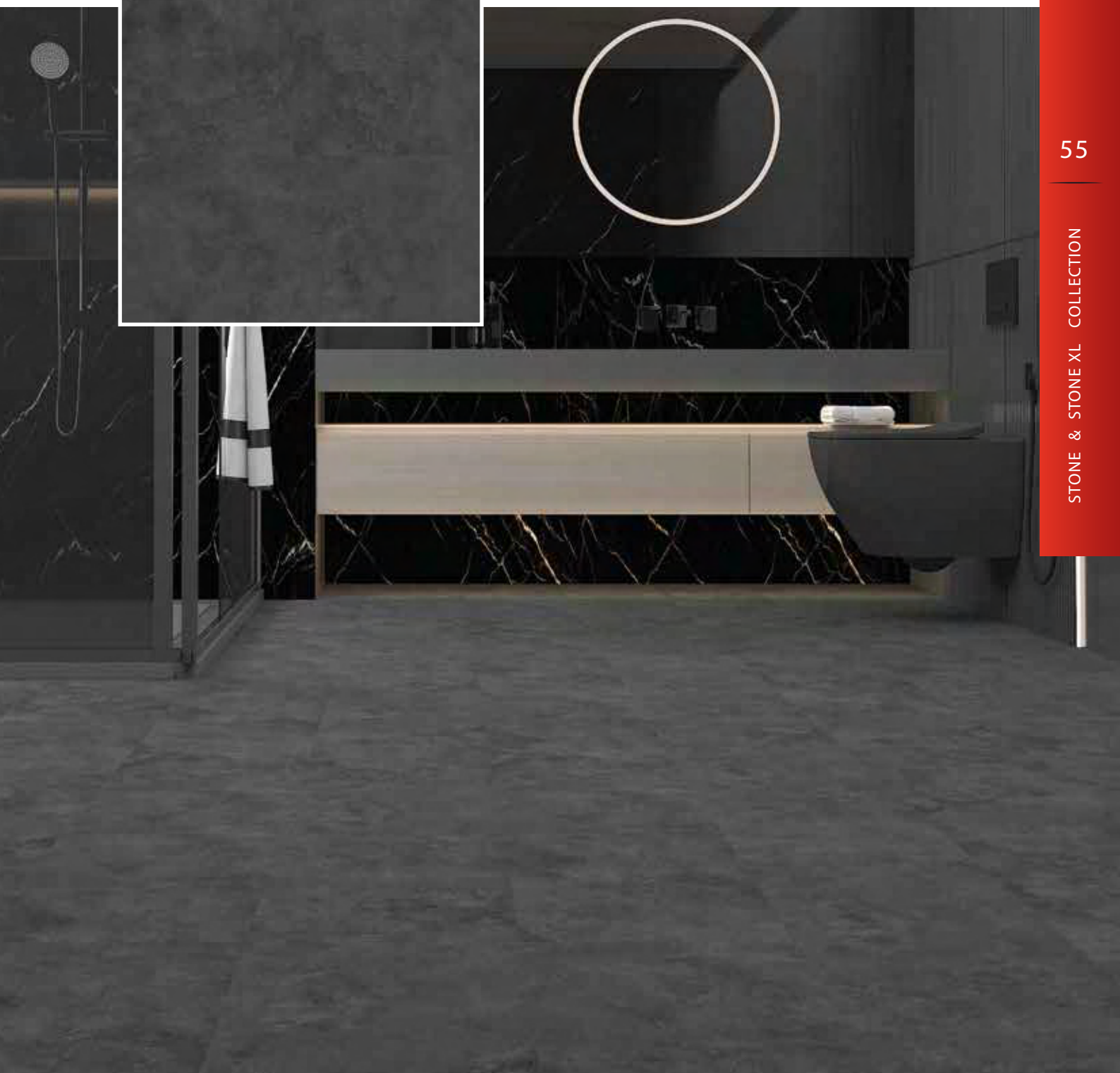
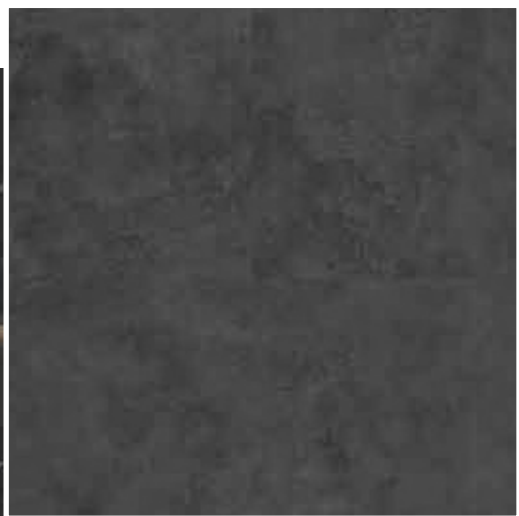



## 805 CARRARA MARMOR



S-805  
305 X 610 X 4 mm



S-805-XL  
305 X 1220 X 5 mm



## 806 BOTTICINO LIGHT



S-806  
305 X 610 X 4 mm



S-806-XL  
305 X 1220 X 5 mm

# 807 MONREAL SLATE



S-807  
305 X 610 X 4 mm



S-807-XL  
305 X 1220 X 5 mm



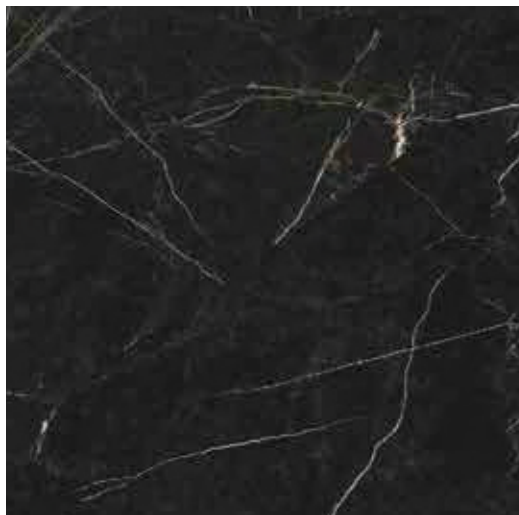

## 808 BOTTICINO DARK





S-808  
305 X 610 X 4 mm



S-808-XL  
305 X 1220 X 5 mm



TECHNICAL SPECIFICATIONS

		SQ Number	Length (mm)	Width (mm)	Thickness (mm)			Pieces box	M <sup>2</sup> box	Weight box (kg)		
WOOD PREMIUM 1	PLANK	Autumn Oak	P1-101-PL	1220	228	5	●	9	2.50	20.20		
		Summer Oak	P1-102-PL	1220	228	5	●	9	2.50	20.20		
		Winter Oak	P1-103-PL	1220	228	5	●	9	2.50	20.20		
		Spring Oak	P1-104-PL	1220	228	5	●	9	2.50	20.20		
		Vintage Oak	P1-105-PL	1220	228	5	●	9	2.50	20.20		
		Cotton Oak	P1-106-PL	1220	228	5	●	9	2.50	20.20		
		Black Oak	P1-107-PL	1220	228	5	●	9	2.50	20.20		
		White Oak	P1-108-PL	1220	228	5	●	9	2.50	20.20		
		HERRINGBONE	Autumn Oak	P1-101-HB	610	150	5	●	●	16	1.46	11.90
	Summer Oak		P1-102-HB	610	150	5	●	●	16	1.46	11.90	
	Winter Oak		P1-103-HB	610	150	5	●	●	16	1.46	11.90	
	Spring Oak		P1-104-HB	610	150	5	●	●	16	1.46	11.90	
	Vintage Oak		P1-105-HB	610	150	5	●	●	16	1.46	11.90	
	Cotton Oak		P1-106-HB	610	150	5	●	●	16	1.46	11.90	
	Black Oak		P1-107-HB	610	150	5	●	●	16	1.46	11.90	
	White Oak		P1-108-HB	610	150	5	●	●	16	1.46	11.90	
	WOOD PREMIUM 2		PLANK	Seashore Oak	P2-111-PL	1220	228	6	●	●	7	1.94
		Pearl Oak		P2-112-PL	1220	228	6	●	●	7	1.94	19.80
Select Oak		P2-113-PL		1220	228	6	●	●	7	1.94	19.80	
Nature Oak		P2-114-PL		1220	228	6	●	●	7	1.94	19.80	
Botanic Oak		P2-115-PL		1220	228	6	●	●	7	1.94	19.80	
Clear Oak		P2-116-PL		1220	228	6	●	●	7	1.94	19.80	
Blond Oak		P2-117-PL		1220	228	6	●	●	7	1.94	19.80	
Taupe Oak		P2-118-PL		1220	228	6	●	●	7	1.94	19.80	
Sahara Oak		P2-119-PL		1220	228	6	●	●	7	1.94	19.80	
Storage Oak		P2-120-PL		1220	228	6	●	●	7	1.94	19.80	
HERRINGBONE		Seashore Oak		P2-111-HB	750	150	6	●	●	14	1.57	15.90
		Pearl Oak		P2-112-HB	750	150	6	●	●	14	1.57	15.90
	Select Oak	P2-113-HB	750	150	6	●	●	14	1.57	15.90		
	Nature Oak	P2-114-HB	750	150	6	●	●	14	1.57	15.90		
	Botanic Oak	P2-115-HB	750	150	6	●	●	14	1.57	15.90		
	Clear Oak	P2-116-HB	750	150	6	●	●	14	1.57	15.90		
	Blond Oak	P2-117-HB	750	150	6	●	●	14	1.57	15.90		
	Taupe Oak	P2-118-HB	750	150	6	●	●	14	1.57	15.90		
	Sahara Oak	P2-119-HB	750	150	6	●	●	14	1.57	15.90		
	Storage Oak	P2-120-HB	750	150	6	●	●	14	1.57	15.90		
	WOOD	PLANK	Canyon Oak	W-201-PL	1220	182	4			11	2.44	19.60
			Dominicano Oak	W-202-PL	1220	182	4			11	2.44	19.60
Havana Oak			W-203-PL	1220	182	4			11	2.44	19.60	
Slate Oak			W-204-PL	1220	182	4			11	2.44	19.60	
Bosland Oak			W-205-PL	1220	182	4			11	2.44	19.60	
Valley Oak			W-206-PL	1220	182	4			11	2.44	19.60	
Desert Oak			W-207-PL	1220	182	4			11	2.44	19.60	
Walnut Oak			W-208-PL	1220	182	4			11	2.44	19.60	
Scraped Oak			W-209-PL	1220	182	4			11	2.44	19.60	
Cambridge Oak			W-210-PL	1220	182	4			11	2.44	19.60	
HERRINGBONE		Canyon Oak	W-201-HB	610	150	4	●	●	20	1.83	14.70	
		Dominicano Oak	W-202-HB	610	150	4	●	●	20	1.83	14.70	
		Havana Oak	W-203-HB	610	150	4	●	●	20	1.83	14.70	
		Slate Oak	W-204-HB	610	150	4	●	●	20	1.83	14.70	
		Bosland Oak	W-205-HB	610	150	4	●	●	20	1.83	14.70	
		Valley Oak	W-206-HB	610	150	4	●	●	20	1.83	14.70	
		Desert Oak	W-207-HB	610	150	4	●	●	20	1.83	14.70	
		Walnut Oak	W-208-HB	610	150	4	●	●	20	1.83	14.70	
	Scraped Oak	W-209-HB	610	150	4	●	●	20	1.83	14.70		
	Cambridge Oak	W-210-HB	610	150	4	●	●	20	1.83	14.70		
WOOD XL	PLANK	Canyon Oak	WXL-201-PL	1220	182	5			9	1.94	20.20	
		Dominicano Oak	WXL-202-PL	1220	182	5			9	1.94	20.20	
		Havanna Oak	WXL-203-PL	1220	182	5			9	1.94	20.20	
		Slate Oak	WXL-204-PL	1220	182	5			9	1.94	20.20	
		Bosland Oak	WXL-205-PL	1220	182	5			9	1.94	20.20	
		Valley Oak	WXL-206-PL	1220	182	5			9	1.94	20.20	
		Desert Oak	WXL-207-PL	1220	182	5			9	1.94	20.20	
		Walnut Oak	WXL-208-PL	1220	182	5			9	1.94	20.20	
		Scraped Oak	WXL-209-PL	1220	182	5			9	1.94	20.20	
		Cambridge Oak	WXL-210-PL	1220	182	5			9	1.94	20.20	
	HERRINGBONE	Canyon Oak	WXL-201-HB	610	150	5	●	●	16	1.57	14.63	
		Dominicano Oak	WXL-202-HB	610	150	5	●	●	16	1.57	14.63	
		Havanna Oak	WXL-203-HB	610	150	5	●	●	16	1.57	14.63	
		Slate Oak	WXL-204-HB	610	150	5	●	●	16	1.57	14.63	
		Bosland Oak	WXL-205-HB	610	150	5	●	●	16	1.57	14.63	
		Valley Oak	WXL-206-HB	610	150	5	●	●	16	1.57	14.63	
		Desert Oak	WXL-207-HB	610	150	5	●	●	16	1.57	14.63	
		Walnut Oak	WXL-208-HB	610	150	5	●	●	16	1.57	14.63	
Scraped Oak		WXL-209-HB	610	150	5	●	●	16	1.57	14.63		
Cambridge Oak		WXL-210-HB	610	150	5	●	●	16	1.57	14.63		
STONE	PLANK	Autumn Oak	P1-101-PL	1220	228	5			8	2.23	23.80	
		Summer Oak	P1-102-PL	1220	228	5			8	2.23	23.80	
		Winter Oak	P1-103-PL	1220	228	5			8	2.23	23.80	
		Spring Oak	P1-104-PL	1220	228	5			8	2.23	23.80	
		Vintage Oak	P1-105-PL	1220	228	5			8	2.23	23.80	
		Cotton Oak	P1-106-PL	1220	228	5			8	2.23	23.80	
		Black Oak	P1-107-PL	1220	228	5			8	2.23	23.80	
		White Oak	P1-108-PL	1220	228	5			8	2.23	23.80	
		PLANK	Autumn Oak	P1-101-HB	610	150	5			6	2.94	18.10
	Summer Oak		P1-102-HB	610	150	5			6	2.94	18.10	
	Winter Oak		P1-103-HB	610	150	5			6	2.94	18.10	
	Spring Oak		P1-104-HB	610	150	5			6	2.94	18.10	
	Vintage Oak		P1-105-HB	610	150	5			6	2.94	18.10	
	Cotton Oak		P1-106-HB	610	150	5			6	2.94	18.10	
	Black Oak		P1-107-HB	610	150	5			6	2.94	18.10	
	White Oak		P1-108-HB	610	150	5			6	2.94	18.10	

## Plank Series variations

RANDOM

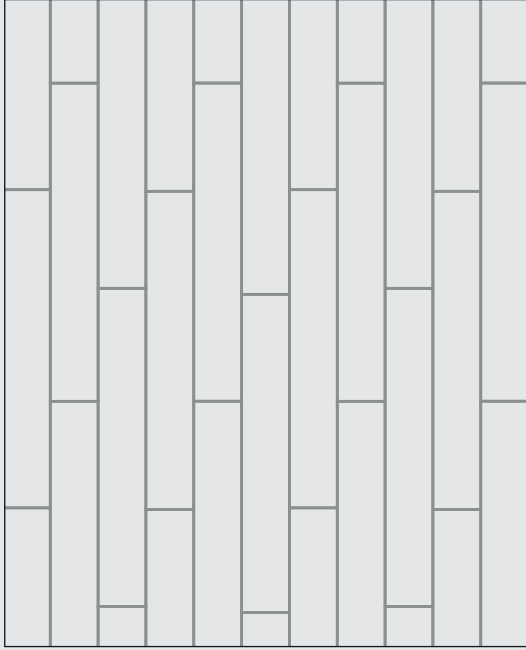

BRICK

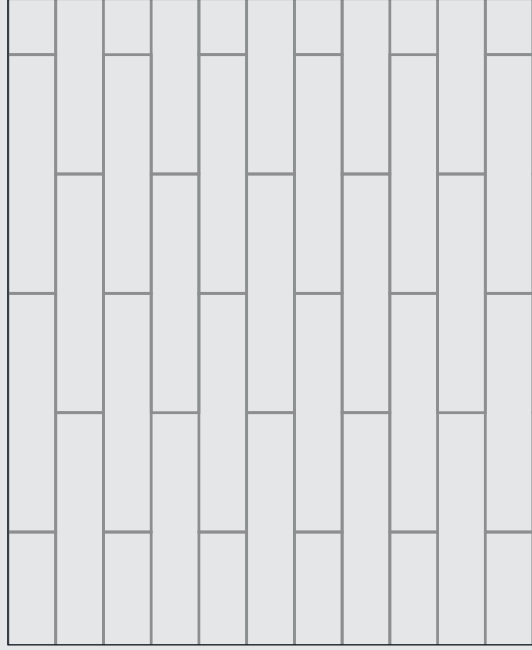

## Herringbone Series variations

SINGLE

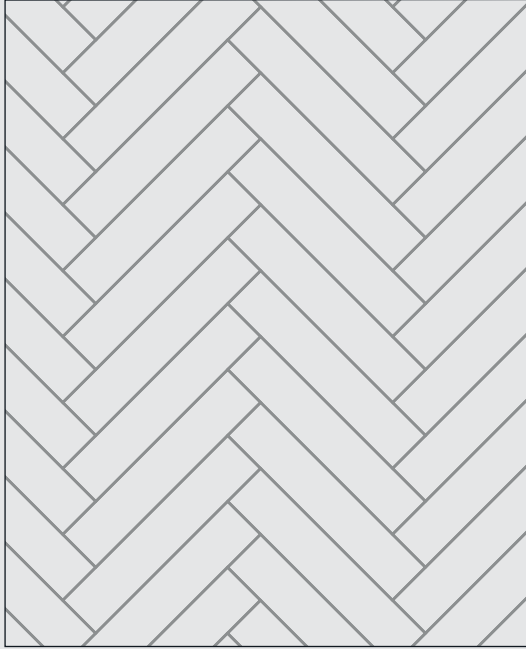

CORNER

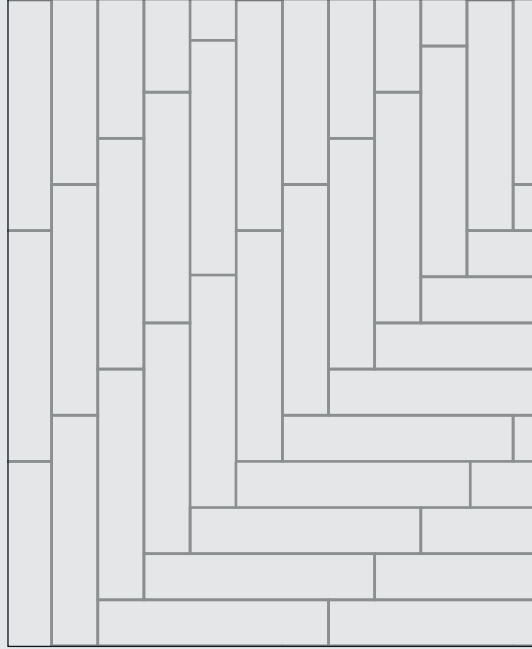

DOUBLE

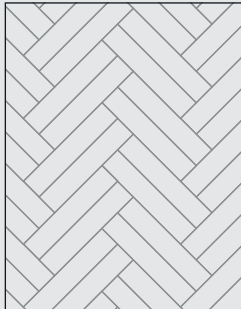

TRIPLE

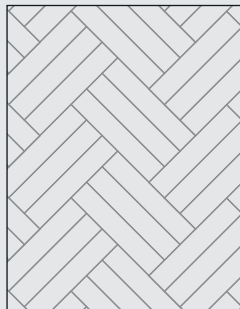

SQUARE

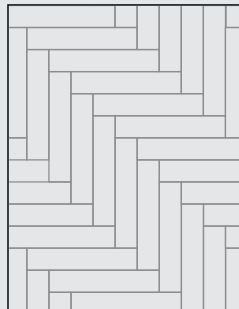

MOSAIC

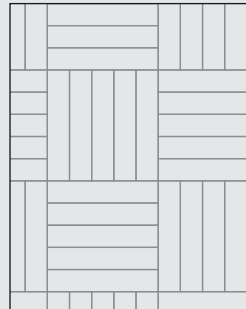



# WOOD PREMIUM



## SPC COLLECTION

WOOD PREMIUM 1 Floors are not only looking like real solid wood, they feel like it.

Thanks to our perfectly established top layers, you will experience all details and structure when you touch the material.

You will notice the remarkable overall layout in differences between the boards, which provide the most natural look a floor can visually establish.



WATERPROOF



QUIET FLOOR



COMFOR TABLE

## TECHNICAL SPECIFICATIONS

### P LANK

FLOORING MODEL	DECOR		MEASUREMENT (mm)	WEARLAYER	UNDERLAY	THICKNESS (mm)
			22 8 X 1220	0,55	YES	5
	EDGE	SURFACE	LOCKING SYSTEM	PACKAGE (m <sup>2</sup> )	PALETTE (m <sup>2</sup> )	CONTAINER 20'
MICRO BEVEL	EMBOSSED IN REGISTER		9 X =2.503 m <sup>2</sup> =20.20 Kg	64 X =160.220 m <sup>2</sup> =1,292.80 Kg	20 X =3,204.40 m <sup>2</sup> =25,856.00 Kg	20

### H ERRINGBONE

FLOORING MODEL	DECOR		MEASUREMENT (mm)	WEARLAYER	UNDERLAY	THICKNESS (mm)
			150 X 610	0,55	YES	5
	EDGE	SURFACE	LOCKING SYSTEM	PACKAGE (m <sup>2</sup> )	PALETTE (m <sup>2</sup> )	CONTAINER 20'
MICRO BEVEL	EMBOSSED IN REGISTER		16 X =1.464 m <sup>2</sup> =11.90 Kg	108 X =158.112 m <sup>2</sup> =1,285.20 Kg	20 X =3,162.24 m <sup>2</sup> =25,704.00 Kg	20



# WOOD PREMIUM



## SPC COLLECTION

WOOD PREMIUM 2 Floors are not only looking like real solid wood, they feel like it.

Thanks to our perfectly established top layers, you will experience all details and structure when you touch the material.

You will notice the remarkable overall layout in differences between the boards, which provide the most natural look a floor can visually establish.



WATERPROOF



QUIET FLOOR



COMFOR TABLE

### TECHNICAL SPECIFICATIONS

#### P LANK

FLOORING MODEL	DECOR		MEASUREMENT (mm)	WEARLAYER	UNDERLAY	THICKNESS (mm)
			228 X 1220	0,55	YES	6
	EDGE	SURFACE	LOCKING SYSTEM	PACKAGE (m <sup>2</sup> )	PALETTE (m <sup>2</sup> )	CONTAINER 20'
MICRO BEVEL	EMBOSSED IN REGISTER		7 X =1.947 m <sup>2</sup> =19.80 Kg	64 X =124.616 m <sup>2</sup> =1,267.20 Kg	20 X =2,492.31 m <sup>2</sup> =25,344.00 Kg	20

#### H ERRINGBONE

FLOORING MODEL	DECOR		MEASUREMENT (mm)	WEARLAYER	UNDERLAY	THICKNESS (mm)
			150 X 750	0,55	YES	6
	EDGE	SURFACE	LOCKING SYSTEM	PACKAGE (m <sup>2</sup> )	PALETTE (m <sup>2</sup> )	CONTAINER 20'
MICRO BEVEL	EMBOSSED IN REGISTER		14 X =1.575 m <sup>2</sup> =15.90 Kg	77 X =121.275 m <sup>2</sup> =1,224.30 Kg	20 X =2,425.50 m <sup>2</sup> =24,486.00 Kg	20



# WOOD & WOOD XL

## SPC COLLECTION

Wood & Wood XL Floors are not only looking like real solid wood, they feel like it.

Thanks to our perfectly established top layers, you will experience all details and structure when you touch the material.

You will notice the remarkable overall layout in differences between the boards, which provide the most natural look a floor can visually establish.



WATERPROOF



QUIET FLOOR



COMFOR TABLE

## TECHNICAL SPECIFICATIONS

### P LANK

FLOORING MODEL	DECOR		MEASUREMENT (mm)	WEARLAYER	UNDERLAY	THICKNESS (mm)
		WOOD				
		182X1220	0,30	NO	4	
		WOOD XL				
		228X1220	0,30	YES	5	
EDGE	SURFACE	LOCKING SYSTEM	PACKAGE (m <sup>2</sup> )	PALETTE (m <sup>2</sup> )	CONTAINER 20'	WARRANTY (Year)
MICRO BEVEL	STANDARD		11 X =2,443 m <sup>2</sup> =19.60 Kg	65 X =158.795 m <sup>2</sup> =1,274.00 Kg	20 X =3,175.90 m <sup>2</sup> =25,480.00 Kg	15

### H ERRINGBONE

FLOORING MODEL	DECOR		MEASUREMENT (mm)	WEARLAYER	UNDERLAY	THICKNESS (mm)
		WOOD				
		150X610	0,30	NO	4	
		WOOD XL				
		150X750	0,30	YES	5	
EDGE	SURFACE	LOCKING SYSTEM	PACKAGE (m <sup>2</sup> )	PALETTE (m <sup>2</sup> )	CONTAINER 20'	WARRANTY (Year)
MICRO BEVEL	STANDARD		20 X =1.830 m <sup>2</sup> =14.70 Kg	84 X =153.720 m <sup>2</sup> =1,234.80 Kg	20 X =3,074.40 m <sup>2</sup> =24,696.00 Kg	15

# STONE & STONE XL

## SPC COLLECTION

THE STONES COLLECTION LETS US COMBINE THE OUTRAGEDOUSNESS AND THOUGHTFULNESS IN ALL OF THE DECORS IN THIS RANGE.

IMMEDIATELY YOU WILL NOTICE THE MODERN STRUCTURE DETAILS AND THE WILD LOOKS OF THE STONES. IN BOTH WAYS, WE HAVE FOUND THE YIN-YANG IN EXPOSING THE FEELINGS OF NATURE AND THE SIMPLICITY OF URBAN LIVING.



WATERPROOF

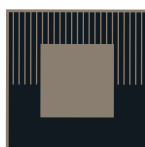









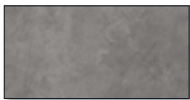

QUIET FLOOR



COMFORTABLE

### TECHNICAL SPECIFICATIONS

FLOORING MODEL	DECOR		MEASUREMENT (mm)	WEARLAYER	UNDERLAY	THICKNESS (mm)
			305 X 610	0,30	NO	4
EDGE	SURFACE	LOCKING SYSTEM	PACKAGE (m <sup>2</sup> )	PALETTE (m <sup>2</sup> )	CONTAINER 20'	WARRANTY (Year)
MICRO BEVEL	STANDARD		8 X  =2.9768 m <sup>2</sup> =23.80 Kg	54 X  =160.747 m <sup>2</sup> =1,285.20 Kg	20 X  =3,214.94 m <sup>2</sup> =25,704.00 Kg	15

FLOORING MODEL	DECOR		MEASUREMENT (mm)	WEARLAYER	UNDERLAY	THICKNESS (mm)
			305 X 1220	0,30	YES	5
EDGE	SURFACE	LOCKING SYSTEM	PACKAGE (m <sup>2</sup> )	PALETTE (m <sup>2</sup> )	CONTAINER 20'	WARRANTY (Year)
MICRO BEVEL	STANDARD		6 X  =2.2326 m <sup>2</sup> =18.10 Kg	72 X  =160.747 m <sup>2</sup> =1,303.20 Kg	20 X  =3,214.94 m <sup>2</sup> =26,064.00 Kg	15

